

**NOTES:**

1. Cyclical Design - UL 2079 Test Standard
2. Do Not screw drywall to slotted track.
3. Sliptrack Systems, System 3 WHI-495-PSV-1333.
4. Reference ITS / Warnock Hersey directory for specific information.

## SYSTEM 3 STANDARD DETAIL HEAD OF WALL PERPENDICULAR TO FLUTE DETAIL

SYSTEM 3 FIRE RATED DESIGN UL-2079 TEST STD.

1





Project: \_\_\_\_\_ Architect: \_\_\_\_\_

Spec. Ref.: Section [09110] [09111] [05400] Date: \_\_\_\_\_

**Sheet Title:**

System 3 Fire Rated Design  
Standard Detail Head of Wall  
Perpendicular to Flute Detail.

**Product:** SLP-TRK®

**Manufacturer:** SlipTrack Systems

**Description:**

SLP-TRK Standard Detail  
SLP-TRK® Brand Slotted Top Track.

**Deflection - 1 inch**

**References:**

- UL-2079 Cyclical Design
- ICC ESR-1042
- OSHPD R-0371-Fixed Equip. Anchorage
- LA City - No. RR25344
- WHI-495-PSV-1333
- UL-R19236

**Assembly Components:****Head-of-wall Track:**

- Manufacturer: SlipTrack Systems
- Model: SLP-TRK®
- Material: minimum 25 ga steel, slotted
- Width: to match steel stud

**Notes:**

- All connections to the structure shall be approved by the project engineer of record.



**Track Only**

Light Gauge Framing  
for Use in Joint Systems  
See UL Fire Resistive Directory

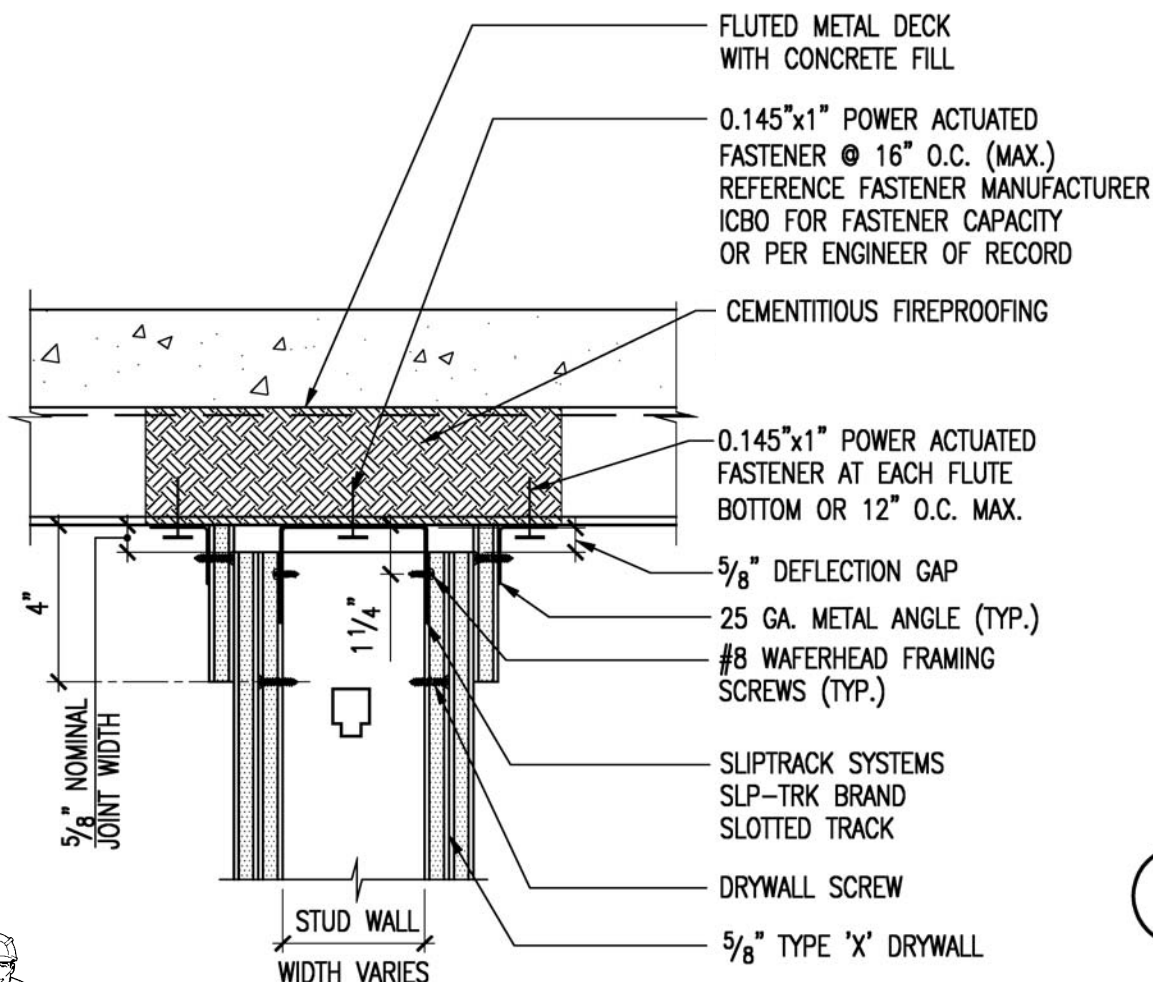

1

File Code - Date: 3/15/11



Building a Better Way.

1-888-4SLPTRK [1-888-475-7875]

www.sliptrack.com