

- NOTES:**
1. Cyclical Design – UL 2079 Test Standard
 2. Do Not screw drywall to slotted track.
 3. All UL Head of Wall Designs vary in nominal joint width. Reference UL directory for specific information based on your selected UL system.
 4. Systems vary in movement capability.

STANDARD DETAIL HEAD OF WALL PERPENDICULAR TO FLUTE

SYSTEM 7-19 FIRE RATED DESIGN UL-2079 TEST STD.





Project: _____ Architect: _____

Spec. Ref.: Section [09110] [09111] [05400] Date: _____

Sheet Title:

System 7-19 Fire Rated Design
Standard Detail Head of Wall
Perpendicular to Flute.

Product: SLP-TRK®

Manufacturer: SlipTrack Systems

Description:

SLP-TRK Standard Detail
SLP-TRK® Brand Slotted Top Track.

Deflection - 1 inch

References:

- UL-2079 Cyclical Design
- ICC ESR-1042
- OSHPD R-0371-Fixed Equip. Anchorage
- LA City - No. RR25344
- NY City - MEA 285-01-M
- UL-R19236

Assembly Components:

Head-of-wall Track:

- Manufacturer: SlipTrack Systems
- Model: SLP-TRK®
- Material: minimum 25 ga steel, slotted
- Width: to match steel stud

Notes:

- All connections to the structure shall be approved by the project engineer of record.
- All UL Head of Wall Designs vary in nominal joint width. Reference UL directory for specification information based on your selected UL system.
- Reference UL Listings (HW-D-0043 sim.) for UL-2079 Design of Choice.



Light Gauge Framing
for Use in Joint Systems
See UL Fire Resistive Directory

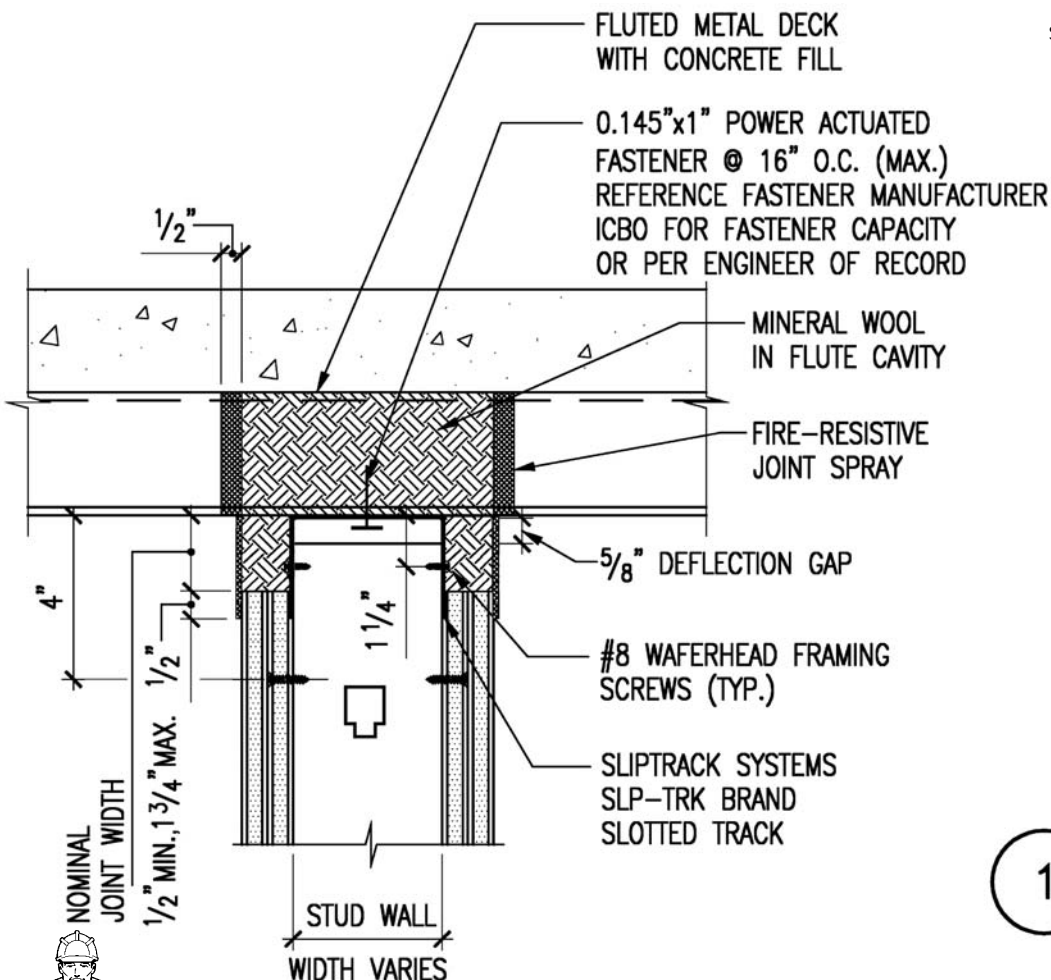

1

File Code - Date: 3/15/11



Building a Better Way.